

The Gorman Progress

Gorman, Eastland County, Texas 76454

Member of Texas Press Association

NUMBER FIFTEEN

MAY 7, 1992

FHA Members Conduct SADD Emphasis Week At GHS



On April 1 - 5, Gorman FHA members conducted Students Against Drunk Driving (SADD) emphasis week at Gorman High School. During the 3-day program, teachers at GHS showed films to their high school students, revealing the damage done to families who have been touched by a drunk driver. On Friday, April 3, FHA members had an all-day demonstration to illustrate the death of an American every 22 minutes, a result of a driver's carelessness. Every 20 minutes, a drum was heard, and a FHA member had her face painted and returned to class wearing a sign which read: "Don't talk to me, I'm just a memory — A victim of a drunk driver." She was not allowed to communicate with the other students for the rest of the day. On Friday afternoon, an assembly was held for Junior High and High School students. Denver Rainey was the speaker and he emphasized the importance of making right decisions.

Actions of the Gorman City Commission

The Gorman City Commission met in regular session on April 9 with the following present: Mayor Pro-Tem John Rice; Commissioners Ann Maxfield, Johnny Smith and Howard Hagood. Others present were Chief Smothers, Joe Williams, Tonya Caraway and Estelle Craddock. Mayor Jack Simpson was absent. The meeting opened at 6:15 p. m. Ann Maxfield made the motion, seconded by Johnny Smith, to accept the minutes. Motion carried 3-0. Howard Hagood made the motion, seconded by Johnny Smith, to approve the bills as presented in the March Bills Report. Motion carried 3-0. Reports were given from Chief Smothers and Supervisor Joe Williams. Judge Huff was absent. Ann Maxfield made the motion, seconded by Howard Hagood to purchase three back braces, one for each crewman at the cheapest price. Motion carried 3-0.

The City Commission of Gorman met in a Called Meeting on April 15th with the following present: Mayor Jack Simpson; and Commissioners Johnny Smith, Ann Maxfield and Johnny Rice. Howard Hagood was absent. The meeting opened at 1:05 p. m. Mayor Jack Simpson gave an up-to-date on the land acquisition for the sewer plant project. John Rice made the motion, seconded by Ann Maxfield, to give Hershell Cordell the authorization to negotiate in behalf of the City (for easements with the adjoining property owners on the sewer plant projects) at a rate of \$10 per hour and mileage of 25 cents per mile. Motion carried 3-0. There being no further business the meeting adjourned at 1:30 p. m. —GP—

Gorman Students Cited For Attitudes And Hard Work

Dear Editor:
What a joy we experiences with Gorman's students! The gifted/talented students in the Gorman fourth through sixth grades attended the WINGS Student Seminars at Region 14 Education Service Center in Abilene on Wednesday, April 23. The students from Gorman school were most courteous and attentive while touring the Paramount Theater and Grace Cultural Center. The docents for Grace Cultural Center and the Paramount's Executive Director all expressed that the time with these was a positive experience. It is always a pleasure to see young people who value learning and guidance. Be sure to express to these students and their teachers your esteem for their attitudes and hard work.

Sincerely,
Cecilia Boswell
Educational Consultant
Gifted and Talented
Vicki Frossard Campbell,
WINGS Coordinator

Jason Ditmore Named Player of the Week In Star-Telegram on April 28

Jason Ditmore of the Gorman Panthers was named as Player of the Week for April 13-17 in the Fort Worth Star Telegram. Jason led in the batting average for all schools with an average of .561 with 23 hits on 41 at bats and scored 21 runs. Also on the Batting Average List was Steve Taylor of the Panthers with a .457 batting average with 21 hits on 46 at bats and he scored 16 runs. In the pitching Earned-Run Average list Jason had an ERA of 1.96 with 54 strike outs while walking 26. In the Home Run List Jason was second with 7, followed by Cory Pack in 6th place with 3. Jason also led the list in Runs Batted In with a total of 32. In this category Steve Taylor had 19. In the Doubles List Jason was fourth with 7. The Gorman Panthers were third in the Team Batting Average with .336, and the Panthers were second in Earned Runs with 1.99. We congratulate these outstanding Panther players.

Voting Very Light In May Election

The turnout for the local school and city elections was very light on Saturday, May 2nd, with 74 ballots being cast in the city election and 106 in the school balloting. John Rice was re-elected to the Gorman City Commission in the only contested position on the ballot. He received 58 votes for Place 2 with Johnny Dorsett receiving 9 votes. Johnny Smith, who was unopposed for Place 4 received 61 votes. Jack Simpson was re-elected Mayor and received 69 votes. A total of 74 votes were cast. Six people filed for the three 3-year terms on the Gorman Independent School Board of Trustees. A total of 123 ballots were cast. Those elected were Danny Snider, who received 105 votes; Larry Keith

Panthers Undeafated In District; Host Huckabay

The Gorman Panthers coasted to their second District win by defeating the Lingleville Cardinals 15 to 1 on April 28th at Gorman. Huerta pitched for Lingleville and he scored the only run in the fourth inning. Pitching for the Panthers was Genaro Madera. Cory Pack scored three runs while Jason Ditmore, Neely Carter and Noah Landa scored two apiece. Scoring single runs were Steve Taylor, Rajee Patel, Don Mauney, Jonray Childers, Genaro Madera and Jeremy Carroll. This win gave the Panthers an 11-4 season mark and they were 2-0 in district. The Gorman Panthers overwhelmed the Eula Pirates 17 to 1 in a non-district game on May 2 at Gorman. Gorman scored in all four innings in which they batted. Jason Ditmore, Noah Landa and Don Mauney all had three runs. Other scorers were Steve Taylor, Neely Carter, Cory Pack, Jeremy Carroll, Jonray Childers, Jade Warren and Genaro Madera. Pitching for the Panthers were Jason Ditmore and Cory Pack. Hubbard scored for Eula in the fifth inning. Pitchers for Eula were C. Smith, Faircloth, White and Fulcher. The Panthers will play host to Huckabay in another District game on May 8th at 4:30.

Gorman Baseball Group Expresses Appreciation

The Gorman Baseball Commission would like to thank Jack Jackson, David Guthery and Tommy Clark for their donations of labor and materials for the pump house for our water well at the ball park. This is and has been greatly appreciated. GIRLS SCHEDULE FOR WEEK Girls Softball games scheduled for this week at Peanut Park are: Tuesday, May 5: Red Chain Terminators vs. Rising Star Angels at 7 p. m. Thursday, May 7: Gorman Rebels vs. Eastland Red Raiders - 7:30 p. m. Friday, May 8: Red Chain Terminators vs. Cisco Hypers at 6:30 p. m. —GP—

Council At Canterbury Villa Held Meeting

On Saturday, April 25th at 2 p. m. the Family Council met at Canterbury Villa. The Family Council is made up of any/all interested family members who have a relative in the nursing facility. Officers were elected. Lane Campbell is president, Barbara Atchison is VP, and Lester Seaton in secretary. Family members present were Barbara Atchison, Lester and Sue Seaton, Odie Brightwell, Beth Dunwell, Lucille Broom, Lane and Ernestine Campbell, Ina Reynolds, Nella Vee Stewart and Larry Campbell. Staff members present were Deane Christian, Adm.; Janet Adams, Assistant Adm.; Frances Rinehart, Dean of Nurses; Johnnie Houghton, RN, and Joy Campbell, activity director. Topics discussed were the alarm system and the need for more aides and LVN' to apply for openings. The meetings are to be held on every other month with the next being on Friday night, June 26th at 8 p. m. —GP—

ITEMS OF INTEREST

Gorman Baseball Association is taking donations for a Garage Sale to be held at the end of the month. Please call Sue Ann Tarver at 734-3218 if you have a donation to be picked up.

NEEDED — Old Pictures of Desdemona town, school and churches for a Big History Project. Copies will be made of originals and returned soon as possible. All this history will be on display each year at the Annual Desdemona Homecoming and School Reunion which is always the Second Saturday in August. Send your old photos, old newspaper clippings, etc. to Vonnie Guthery, P. O. Box 187, Desdemona, Tx 76445. The Class of 1992 will be having a CAR WASH Saturday, May 9. Bring your car to Citizens State Bank in Gorman and let us clean your car, truck or van. Also we are having a BAKE SALE on May 9 just before Mother's Day held in front of the Post Office. We would appreciate each and everyone's support. All funds are greatly appreciated. Once more we would like to say Thanks to everyone that has supported our class in anyway. We have come a long way and could not have done it without everyone's help. Thanks A Lot - Class '92

Canterbury Villa of Gorman would like to remind everyone that Blood Pressure Checks are free to the Public at anytime.

OUTREACH HEALTH SERVICES - PAT CORNWELL, R.N.
Blood Pressure and Blood Sugar Clinic will be held on the Second Wednesday of each month at the Gorman Hotel Apartments and the Third Wednesday of each month at Senior Citizens Center from 10:00 a.m. to 12:00 noon.

The Gorman Peanut Festival Committee meets on the Second Wednesday of Each Month at 8:00 p.m. in the School Cafeteria. Make plans to come to the meeting.

STATED MEETINGS FOR GORMAN MASONIC LODGE NO. 716 ARE SECOND TUESDAYS OF EACH MONTH AT 7:30 P.M. VISITORS ARE MOST WELCOME, AND MEMBERS ARE URGED TO ATTEND. ELWOOD RAGLAND, MASTER 758-2552, HOWARD HAGOOD, SECRETARY 734-2977.

Gorman PTO is accepting Donations for the Louise Rankin Memorial Library. If you would like to make a Donation in Memory of or In Honor of Someone, Please Call Janda Taylor at 734-2497 or 734-2617

Gorman Primitive Baptist Church has Services on 2nd - 3rd - 4th Sundays. Services begin at 10:30 a.m. Elder Barry Brown, Pastor - Everyone Welcome To Attend.

The Order of the Eastern Star holds its regular stated meetings on the first Monday of each month at 7:30 p.m. - Ann Jay, Worthy Matron - 734-2733 and Howard Hagood, Worthy Patron 734-2977..

NANCY TROUT WILL BE IN GORMAN THE THIRD WEDNESDAY OF EACH MONTH AT THE CITY OFFICE TO RENEW AUTO LICENSE PLATES. HER NEXT VISIT WILL BE MAY 20TH FROM 9 - 12 NOON.

SECOND FRIDAY NIGHT MUSICAL will be held Friday, May 8th at the Old Gorman Fire Hall. Concession stand will open at 5 p. m. and music will get underway at 6 p. m. All musicians are welcome, as well as listeners.

School Honor Roll For Fifth Six Weeks

- PRINCIPAL'S A4 AWARDS**
KINDERGARTEN A. M.
Herminio Velasquez, David Earles
KINDERGARTEN P. M.
Holly Abbe, Emily Thornton
FIRST GRADE (Burlison)
Derrick Adams, Carrie Shipp
FIRST GRADE (Smith)
Josh Bridges and Channing Hanzel
SECOND GRADE (Lasater)
Raquel Garcia and Jody Perez
SECOND GRADE (Reeves)
Mark Sanders and Angie Marin
THIRD GRADE (Gibbs)
Matt Swanner and Jessica Lara
THIRD GRADE (Caraway)
Raul Madera and Eva Rodriguez
FOURTH GRADE (Good)
Pam Osborne and James Hogan
FOURTH GRADE (Harrington)
Levi Roberts and Shawn McCauley
FIFTH GRADE (Bear)
Samantha Goode and Cody Carlton
SIXTH GRADE
Janice Glover and Anette Snell
HONOR ROLL
First Grade (Burlison)
A Honor Roll
Derrick Adams, Dusty Arnold, Mary Landa, Tana Goode, Russell Jay, Shari Marlow, Sean Rountree and Rolando Torres.
A-B Hpnpr Roll
Wesley Herron, Linda Olivares, Dawn Roberts, Carrie Shipp and Terri Smith.
FIRST GRDAE (Smith)
A Honor Roll
Josh Bridges, Sherry Carlton, Kristina Everton, Channing Hanzel, Sarah Lewis, Mayra Lopez and Jessica Snell.
A-B Honor Roll
Crystal Ibarra and Joel Espinoza.
SECOND GRADE (Lasater)
A Honor Roll
Sonya Burgess, Jacob Johnson, Enrique Madera and Cory Streiff.
A-B Honor Roll
Jasmine Burns, Christopher Cox, Charla Davis, Barbara Eaves and Jason Hogan.
SECOND GRADE (Reeves)
A Honor Roll
Justin Brown, Keith Treadway, Mandy Warren, Rachel Mayfield and Billy Grissom
A-B Honor Roll
Seth Griffin, Zachary Sanders, Daniel Patel, Michael Leal, Catie Davis, Mark Sanders and Tina Sanders.
THIRD GRADE (Gibbs)
A Honor Roll
Emerald Guthery, Casey Simpson, Krissy Roberts, Cody Simpson and Kristina Turner.
A-B Honor Roll
Danny Barbee, Jessie Hagood, T. J. Jay, Josh Johnson, Angelica Landa, Jessica Lara, Terry Perez, Kendra Roberts, Matt Swanner and Mike Torres.
THIRD GRADE (Caraway)
A Honor Roll

Anna Laura Clearman To Host Kokomo EH Club

The Kokomo Extension Homemakers Club will have their regular monthly meeting in the home of Mrs. Anna Laura Clearman on Monday, May 11th at 2 p. m. Eastland County Extension Agent Janet Thomas will give the program "Illiteracy in Texas." Kokomo Club members are urged to attend. Prospective members and guests are welcome. Reporter, Nancy Hendricks —GP—

Gorman 8, Jim Ned 3
Jim Ned 600 021 0 - 3 7 1
Gorman 600 011 x - 7 5 3
Johnson, Hicks (1) and Ray, Dittmore and Mauney, WP — Dittmore 6-2, LP — Johnson, 2B — Jim Ned, Pemberton; Gorman, Mauney, Childers, HR — Jim Ned, Puschel. Records — Gorman 13-4, Jim Ned 5-11.

Kristin Gibbs, Mark Glover, Beatriz Ramirez, Irma Lopez and Christina Mauney.
A-B Honor Roll
Erika Hipolito, Eva Rodriguez, Brandon Powell, Jackson Thacker, Bobby Walton, Michael Foster, Raul Madera, Robert Granado and Theresa Petree.
FOURTH GRADE (Good)
A Honor Roll
Sheryl Everton, Robert Lewis, Manuelita Madera and Pam Osborne.
A-B Honor Roll
William Curb, Chris Fox, Bradley Gilmore, James Hogan, Alma Sanchez, and Cole Sandlin.
FOURTH GRADE (Harrington)
A Honor Roll
Blacia Bear, Brenda Ibarra and Shawn McCauley.
A-B Honor Roll
Bobbie Jo Grissom, William Hagood, Levi Roberts, Josie Thacker, Adrian Torres and Ashley Rich.
FIFTH GRADE (Bear)
A Honor Roll
Ruth Reeves, Samantha Goode, Jodi Norris and Belinda Snider.
A-B Honor Roll
Ashley Laminack, Francisco Madera, Margarito Sanchez, Brandy Streiff, Jessica Walton, Sonya Reagan, Jason Perez, Patricia Rodriguez, Cody Carlton, and David Rone.
SIXTH GRADE (Taylor)
A Honor Roll
Samantha Stephens, Sarah Reeves and Janice Glover.
A-B Honor Roll
Clay Sandlin, Kaycee. Gilmore and Claudia Ibarra.

The staff and residents of Canterbury Villa of Gorman Nursing Home would like to invite everyone to come and visit us during Nursing Home Week, May 10 thru 16. We will be having a Salad Supper for our residents' families, Tuesday, May 12 at 7:00 p.m. and on Thursday, May 14 at 7:00 p.m. a supper for the Gorman Fire Department.

FULLEN SERVICE CENTER

305 EAST MAIN P. O. BOX 629 EASTLAND, TEXAS 76448

GENERAL MOTORS
GASOLINE ENGINES NORMAL CONDITIONS
LOCAL AREA RECOMMENDATIONS

INTERNAL CODE	SCHEDULED MAINTENANCE SERVICE	3,000	6,000	12,000	18,000	24,000	30,000	36,000	42,000	48,000	54,000	60,000	COMMENTS OR ADD. SERVICES
1000099503	LUBE, OIL & FILTER CHANGE	19.95	19.95	19.95	19.95	19.95	19.95	19.95	19.95	19.95	19.95	19.95	RECOMMENDED EVERY 3,000 MILES
4480051514	WHEEL BEARING ADJUST & REPACK REAR WHEEL DRIVE ONLY - 2 WHEELS					49.95					49.95		
0000000000	DRIVE BELT INSPECT & ADJUST	FREE	FREE	FREE	FREE	FREE	FREE	FREE	FREE	FREE	FREE	FREE	RECOMMENDED EVERY 3-4,000 MILES
0000000000	AIR FILTER INSPECTION	FREE	FREE	FREE	FREE	FREE	FREE	FREE	FREE	FREE	FREE	FREE	AIR FILTER ADDITIONAL IF REQUIRED
2560183508	COOLANT SYSTEM FLUSH & REFILL - INCLUDES 2 GALLON COOLANT					43.95					43.95		
1295000004	TIRE ROTATION - INCLUDES FREE BRAKE INSPECTION	12.95	12.95	12.95	12.95	12.95	12.95	12.95	12.95	12.95	12.95	12.95	
3200278510	AUTOMATIC TRANSMISSION TRANSAXLE SERVICE					59.95					59.95		
0000000000	EXHAUST SYSTEM CHECK	FREE	FREE	FREE	FREE	FREE	FREE	FREE	FREE	FREE	FREE	FREE	
3600138514	ENGINE TUNE UP, SET TIMING, ADVANCE CHECK & SPARK PLUG REPLACEMENT - 6 CYL.					49.95					49.95		+\$15.00 FOR 8 CYLINDER +\$15.00 FOR 4 CYLINDER
0000000000	THROTTLE LINKAGE CHECK	FREE	FREE	FREE	FREE	FREE	FREE	FREE	FREE	FREE	FREE	FREE	
	REPLACE WIPER, CHECK OPERATION OF WIPERS AND WASHER, AND FILL WASHER												- A N N U A L L Y -
2200099507	DIFFERENTIAL SERVICE - DRAIN FLUID AND REPLACE WITH NEW DIFFERENTIAL FLUID					29.95					29.95		

SOME RESTRICTIONS APPLY -- PRICES SUBJECT TO CHANGE WITHOUT NOTICE

DIRTY OIL?

CLEAN UP AT
FULLEN SERVICE CENTER

Nothing wears out your engine quicker
than dirty oil. So take advantage of our

\$19.95

OIL, FILTER & LUBE SPECIAL.

For best results, we use genuine GM
Goodwrench motor oil and AC filters,
the products designed for your GM
car or light truck. See your owner's
manual for the right service interval
for your vehicle.



Mr. Goodwrench



FULLEN SERVICE CENTER

305 EAST MAIN - P. O. BOX 629 - EASTLAND, TX
SERVICE HOURS: MONDAY - FRIDAY 8:00 A.M. - 6:00 P.M.



PHONE (817) 629-2676
SERVICE BY APPOINTMENT

CANTERBURY VILLA

NEWS

NANCY HENDRICKS - REPORTING

The April birthday party was Thursday, April 30th at 2 p. m. Honorees were Varona Taylor, Hillery Seay, Mary Stanley and Ola Walker.

Orvil and Jenny Newcomb entertained. Scott Lewis sang a special "Jesus Loves Me".

Birthday ake and punch were served to everyone present. The honorees received shampoo from Canterbury Villa, lotion from the Church of Christ, Kleenex from First Baptist Church and lotion from the United Methodist Church.

Those baking cakes were Anna Rush, May Fry, Dixie Pack and Velma Bennett.

Guests were Pauline Allen, Scott Lewis, Bonnie Cox, Anna Rush, Orville and Jenny Newcomb, Nancy Hendricks, Velma Bennett, Dixie Pack and May Fry.

Mr. and Mrs. Don Loudermilk of De Leon and Mr. and Mrs. Jack Boyd of Desdemona visited Orville Boyd.

On Wednesday Nancy Hendricks and Irene Hallmark came for bingo. Winners were Cynthia Earles, Ora Mae Atchison, Ruby Vandergriff, Henry Rice, Jess Hallmark, Garnett Adams, S. D. Gilmore, Iola Johnson, Dorothy Beaty, Emma Shugart, Ida Lewis and Veno Hale.

We are happy to report Pauline Love and Gertie Leeper are home from the De Leon Hospital.

Lenis Rice, Irene Hallmark and Nancy Hendricks helped with bingo. Winners were Veno Hale, Jess Hallmark, S. D. Gilmore, Emma Shugart, Iola Johnson, Ora Mae Atchison, Henry Rice, Gertie Leeper Cynthia Earles and Ruby Vandergriff.

Clarence Ragland visited Garland Perry on Friday.

Lenis Rice visited Iola Johnson on Friday.

On Thursday morning we had Bible Study with Joy Campbell for 10 residents.

Those coming for the Friday musical were Bernice Farley, Bernard and Ann Keith, Dewey Bailey, Raymond and Vivian Hart of Ranger.

Those visiting Gertie Leeper were Rhoda Burney, Rosemary Burney of Comanche, Eddie Woodall, Moses

Fannin, Robert Cox, Robert Sanders, Zachary Sanders, Nellie Lucky and Norman Tedford and Ola Walker.

We are sorry to report Dorothy Burns is in the De Leon Hospital.

On Thursday we sure enjoyed the Pet Parade. Those showing pets were Shannon Mauney - puppy; Clint Jones - fish; Judy Newton - two finch birds; Kristie Hallmark - 4 kittens. Other guests were Tammy, Taci and Skylet JONES* Louise and Bill Taylor and Eunice Love.

Those visiting Annie and Veno Hale were Mamie and Betty Little and Joan Williams.

On Monday Nancy Hendricks helped with bingo. Winners were Jess Hallmark, Veno Hale, S. D. Gilmore, Dorothy Beaty, Emma Shugart, Iola Johnson, Garnett Adams, Henry Rice, Laverne Kennedy, Cynthia Earles, Ruby Vandergriff and Ora Mae Atchison.

Those visiting Ora Mae Atchison were Jessie Elvin, Ruby Dale and Yvonne Atchison, Barbara and Chesley Atchison of Fort Worth and Ima Lee Bureson of Desdemona.

It sure was fun for 9 residents to make animals with play dough for Monday exercises.

Mr. and Mrs. Marvin Jones of Dublin visited her brother, Eulon Perry, on Tuesday.

Seven residents enjoyed the guess ing game contest led by Joy Campbell on Monday.

Lestie Tonn of Eastland visited his aunt, Nancy Holloway.

On Tuesday morning we had resident council meeting and 16 residents then enjoyed playing games.

Billie Stacy visited Buddy McClearen.

On Tuesday those coming for the 2:30 singing were Billie Stacy, Cricket Walker, Hazel Campbell, Dorothy Jackson from Carbon, Leslie Tonn of Eastland, Dorothy Roberts of Desdemona, Melba Frasier, Willo Rice, Rev. and Mrs. L. C. Landers, Opal Mauney, Lillie McCloud, Joe O'Neal, Nancy Hendricks, Anna Rush, Estelle Erwin, Irene Hallmark Bernice Rodgers and Joy Campbell.

Era Maupin visited with Cynthia Earles.

Dorothy Roberts gave Cleo Clement a new permanent.

Those visiting Ida Lewis were Ora Lee Lawrence, Jimmy Lewis and Joe O'Neal.

On Saturday Rev. Joyce Dennis of aylor Chapel Methodist Church, Robert Abbott and Rev. Joe O'Neal of Kokomo Baptist brought church services for 16 residents.

Those visiting Homer Wood were Norman and Velsie Rawson of Cisco, Sterling McCauley and Daisy Slaton.

On Sunday morning Rev. Ron Carroll of First Baptist Church taught the Sunday school lesson for 10 residents.

Those visiting Emma Shugart and S. D. Gilmore were Dixie Pack of Desdemona, Bill and Odalee Thomas of Breckenridge, Joe O'Neal, Doyle

Poynor, Bud and Dee Smithey, Modell Burgess and Idell Warren.

At 2:30 those coming for Sunday worship from First Baptist Church at Carbon were Rev. Keith Henson, Billie Stacy, R. Lee McDaniel, Gladys Hale, Cricket Walker, Hazel Campbell, Truitt and Pat Spruill, Euell Allison and C. O. Snadlin.

VARONA TAYLOR HONORED

Pauline Allen honored Varona Taylor on her birthday with a party in the Allen home. Those attending were Dorothy Hatcher, Janda and Tracey Taylor, Bonnie Cox, Brad, Paula, Megan, Wesley and Scotty Lewis, Pauline Allen and the honoree, Varona Taylor.

At 4 p. m. those coming from the

Church of Christ were Bro. T. A. Grice, Bro. and Mrs. Curtis Maness, Dora Faye Brewer, Lorene Foster, Georgie and Frankie Stacy, Clara Mae Frossard, Floydene Gilbert, Bud and Dee Smithey, Juanita Files, Zena Simpson and Odie Brightwell.

Mr. and Mrs. J. W. Torrance of Comanche visited Ina Mae Tarrance.

On Wednesday Rev. L. C. Landers brought the devotional for 10 residents.

The little garden is growing and we are now eating fresh radishes and green onions.

Those visiting Cleo Clement and Mae Quinn were Glen Clement, Lester and Sue Seaton, Joe O'Neal,

David Seaton of Blue Mound, Mayvis Lasater, Marie White, Anna Rush, Estelle Erwin and Opal Mauney.

Seniors

See our fine selection of graduation supplies.

TOP QUALITY

ECONOMICAL PRICES

FAST SERVICE

Gorman Progress

What costs less to keep than a guard dog?

A SAFE DEPOSIT BOX!

Ask us about a Safe Deposit Box today.



Citizens State Bank

Phone 734-2255 — Gorman, Texas



FINAL CLOSEOUT SALE

Last Three Days - Thursday/Friday/Saturday

10% - 20% - 30% OFF

Entire Store Merchandise

NOTE: All customers with consignments still in our hands - must pick them up before May 15th. Please make arrangements to come by before that date.

THANK YOU

I would like to thank everyone for their kindness to us. We appreciate everyone so much. It's been fun. Again, Thank You.

G.W. and Emily Gilmore

Brandees Consignment Shop

Downtown Gorman, Texas

Don't forget Mom!

(Mother's Day is May 10)

Choose From Our Selection of

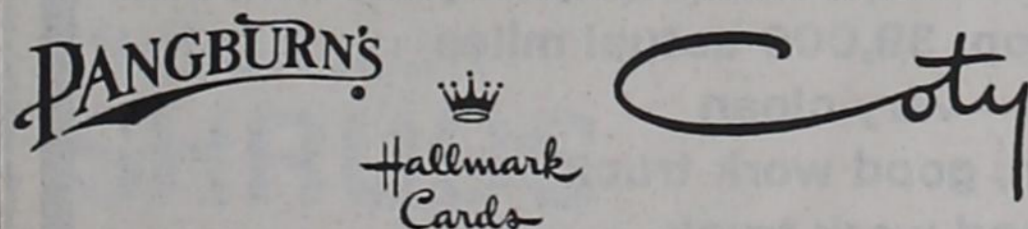

* Hallmark Cards

* Coty and Max Factor Cosmetics

* Pangburn's

Millionaire Chocolates

Gorman Pharmacy

George Simmons, Pharmacist
Phone 817-734-2859
Downtown Gorman

Eastland denied detachment from district

By MAYBIE LE TROUT
Correspondent

EASTLAND — Eastland school officials denied a request Monday night to detach about 43,000 acres from the Eastland school district and add it to the Gorman school district.

More than 100 people crammed into the Eastland High School cafeteria to speak for and against the detachment, and then board trustees met briefly in executive session and announced their decision.

Board member Gene Kea read a prepared statement outlining the reasons behind denying the detachment request. They included:

- It would not be in the best interest of the children,
- It would increase taxes, and
- Several people spoke against the proposal.

The decision will be appealed to the state commissioner of education within 45 days, according to Edgar Coble, attorney for the group seeking the detachment.

The area formerly was part of the Carbon district, which dissolved about two years ago. After a series of meetings attended by a state monitor, the Carbon school board voted to become part of the Eastland school dis-

trict.

At that time, people living in the eastern part of the Carbon school district were not allowed to detach and join the Gorman district.

They claim, however, that Eastland school officials assured them that the detachment would be allowed at a later date.

"We feel representatives of the Eastland Independent School District promised us we could do this and (we) would be unopposed," said David Guthrie, who lives east of Carbon and has enrolled his children in Gorman school anyway.

Many students affected continue to transfer to Gorman, and Coble said children should be a part of the school district closest to their home.

"Many participate in Gorman activities such as church and social gatherings," he said. "These people are your neighbors; we ask you to bring to a conclusion what was begun two years ago."

After the board voted the proposal down, Superintendent Keith Watkins told the crowd he hopes everyone can remain friends.

"I understand there will be some hard feelings," he said. "As Gorman did as it felt best, we of the Eastland Independent School District did as it felt best."

KOKOMO NEWS

By Zelda Jordan

A large crowd gathered at the Simpson Cemetery on Saturday, May 2 for the annual meeting of the Kokomo-Simpson Cemetery Association held at the tabernacle. The business meeting began at 11 a. m. with Delmon Eaves, president of the Association, presiding. The minutes of last year's meeting were read by the secretary, Zelda Jordan, and they were approved as read. Joyce Eaves gave the treasurer's report in the absence of the treasurer, Norma Webb, who could not be there. The report was approved as given.

Small American flags had been placed at the graves of all known veterans buried in the three cemeteries, the Mangum Family Cemetery, the Kokomo Cemetery, and the Simpson Cemetery. Mr. Eaves stated if anyone knew of other veterans buried in any of these cemeteries to please let jim know and a flag would also be placed at their graves. The flags did look very nice in the well kept cemetery.

Recognition was given to Sarah Hendricks Tuggle as the oldest one present; to Christopher Treadway, 4 months old, son of Nolan, Jr. and Christie Treadway of Midland, and to Melanie Karianinen, just two weeks younger than Christopher, and daughter of Ernie and Teresa Karianinen of Midland, for both being the youngest present. Both babies are the grandchildren of Nolan and Linda Treadway fo Snyder. Recognition was also given to Jack Hopper of Roswell, N.M. for coming the farthest.

Special recognition was given the descendants of Mr. Simpson, who gave the first land for the cemetery, who were present. They were Billie Hammond, Terry J. Hammond, Fred and Kathryn Hammond and Dorothy Locke, all of Brownwood, and Melissa Mullins of Fort Worth.

Bobbi Brown, a past treasurer of the association, and now a lifetime trustee of the perpetual fund , was unable to be with us this year due to surgery on a broken hip, but she was given a round of applause and thanks for the dedicated and good job she has done for the Cemetery Association. Bobbie, we missed you and wish you a speedy recovery.

The terms of two committeemen, Bill Eaves and Wilbourne Wood, expired this year. Bill asked to be replaced. Wilbourne Wood and Patsy Collins were elected to three year terms.

There being no further business, the meeting adjourned at 11:45 and most of the people present gathered at the Kokomo Community Center for lunch and more visiting.

J. W. and Glenna Davis of Lake Leon and Mrs. Hudson and Mrs. Lyerla of Flatwoods were visitors at the Kokomo Baptist Church on Sunday morning. Jimmy Little led the music with Glynda Bond at the piano.

Woodrow and Helen Browning attended the all-day singing at Rock Bluff on Sunday. Berneice Rodgers attended the singing in the afternoon.

Jack and Lorene Eldridge of Seattle, Wash. visited last week with her brother and sister-in-law, Claude and Juanita Fuller. Rick and Pat Fuller of Lewisville and Wesley and Kevin Fuller of Abilene were weekend visitors with the Fullers.

Sheri Snider of Stephenville visited on Sunday with her grandmother, Mrs. Hazel Snider.

Mrs. J. C. Clearman spent the weekend with Jamie and Ann Clearman at Ovalo. Mike, Mary Jo and Kami Leonard of Canadian met them there and they all attended the track meet at ACU in support of the Canadian track team. Kami Jo Leonard is a member of the Canadi-

an track team and participated in three events.

On Saturday morning they all attended a program at First Baptist Church to see Kaylee Whitehurst's day care class. They attended church at Lawn First Baptist Church on Sunday morning.

Jamie and Ann Clearman came home with Mrs. J. C. Clearman for an afternoon visit on Sunday afternoon. Ken Clearman of Grand Prairie visited with Mrs. Clearman on Thursday.

Verna Laminack and Louise Brown of Lake Jackson and Virda Mae Norris of Fort Wprth and Verda Jean Eaves of Mangum visited with Delmon and Joyce Eaves during the weekend and attended the Kokomo-Simpson Cemetery meeting and homecoming on Saturday. Glenn and Zelda Jordan visited with them in the afternoon on Saturday.

Sylvia and Kelly Buchanan and Kimberly Hobbs of Clyde spent Sunday with Mrs. Albert Hendricks. Sylvia and Nancy visited with Glenn and Zelda Jordan on Sunday evening.

Elvis and Johnnie Chambers of Comanche and Billy Strube of De Leon visited with Larry and Betty Strube on Sunday.

Cliff and Doris Graham of Monahans and her sister, Thina Pierce of Wink have been visiting with Delmon and Joyce Eaves. Zelda Jordan visited with them on Tuesday afternoon.

We are happy that Mr. Buster Johnson of Carbon was released from Humana Hospital and is recuperating at the Valley View Lodge in Eastland. We send get well wishes to him.

Several from the community attended the Eastland School Board meeting on Monday night. They are among the group that are asking that their land that was formerly in the Carbon School District be released so it may be annexed to the Gorman School District. It was very obvious that the Eastland School Board's minds were made up before the meeting not to release the land. After nearly an hour and a half of hearing statements from both those who want land released and those who don't, the board took only a very few minutes to meet in executive session before reading a report stating the reasons they would not release the land from the Eastland School District.

It was our understanding taht at the time the Carbon School District was dissolved, the superintendents of the Eastland and Gorman Schools agreed that after one year those who wanted to attach their land to the Gorman School District would be allowed to do so. This agreement has not been honored by the Eastland School District.

It has been stated in the Eastland Telegram twice that the Carbon School District was annexed with the Eastland School District by elections of each district in 1990. This is not a

SENIOR CITIZENS NEWS

BY MOZELLE RHYMES

Beth Anderson visited on Sunday with her mother, Mozelle Rhymes.

This week Agnes Hodges tells what she likes about the Center. Agnes is another of our regulars and volunteers.

"I enjoy the Senior Center because the food is nutritious and there are no dishes to wash. And it's a good place to make friends".

Agnes Wyatt Hodges
—GP—

CARD OF THANKS

We want to thank the Gorman Fire Department, the Eastland Fire Department and the Ranger Fire Department for the quick response to put out the tank battery fire early Monday morning on our place north of Kokomo. The tanks were struck by lightning and exploded into fire and spilled the oil out into the ditches along the highway. It could have been a very dangerous situation if it had not been for these brave men who put their lives on the line to bring the fire under control. We are very grateful to them all. The oil lease is owned by Bill Neill of Abilene and I'm sure he is very grateful, too.

Glenn and Zelda Jordan
—GP—

Methodist Mission Home To Conduct Adoption Orientation

The Methodist Mission Home of San Antonio will hold an all-day orientation for prospective adoptive parents at First United Methodist Church, 800 West 5th Street, Fort Worth, on Saturday, June 27th from 10 a. m. to 4 p. m. The cost is \$50 per couple. For advance registration, call (512) 696-7021 to assure yourselves a space and materials. You can register at the door.

Bryce Hatch, Director of Maternity and Adoption Services for the home, will conduct the meeting. "Most couples, who have worked with us during the past year, have received a baby quicker than they ever thought possible," Hatch said recently. You could be the parents of an adopted child sooner than you think! Call for reservations today!

trua statement, unless you count just the vote of the two school boards as elections. We land owbers and taxpayers have had no choice in the matter at all. Does this seem fair? I don't think so. Our land is in the southeastern edge of the Carbon School District. In fact our land is divided on our home place with part of it being in the Gorman School District and the other part in the Carbon School District. We would rather it all be in one district, preferably the Gorman School District.

NEW 1991 LEFTOVER UNITS

- 1991 Chevrolet Geo Prizm 4-Dr
- 1991 Olds Custom Cruiser S Wagon
- 1991 Olds 98 Regency Elite 4-Dr
- 1991 Olds Cutlass Supreme S/L 4-Dr
- 1991 Olds Calais S 4-Dr

USED CARS

- 1991 Chev. Corsica 4-Dr, V6, Cruise, Tilt, 13,000 miles
- 1989 Olds Calais 2-Dr, 23,000 actual miles
- 1991 Chev. Geo Prizm 4-Dr, 11,000 miles
- 1991 Buick Century 4-Dr, fully loaded, 8,700 miles
- 1991 Geo Metro 4-Dr, Automatic, air, 12,000 miles
- 1991 Olds Cutlass Supreme, 2-Dr, fully loaded, 10,000 miles
- 1990 Chev. Lumina 4-Dr, fully loaded, 47,000 miles
- 1992 Olds Delta 88 LS 4-Dr, fully loaded, 8,000 miles
- 1992 Chev. Caprice 4-Dr, Fully loaded, 7,500 miles
- 1990 Olds 98 Regency Brghm 4-Dr, 30,000 miles
- 1991 Olds Calais 2-Dr., fully loaded, 18,000 miles
- 1991 Pontiac Grand AM LE 2-Dr., cruise, tilt, 18,000 miles
- 1989 Olds 98 Regency Brghm 4-Dr, loaded, 46,000 miles
- 1991 Chev Lumina 4-Dr, fully loaded, 14,000 miles
- 1991 Chev. Cavalier R/S 4-Dr, 11,000 miles
- 1989 Buick Park Ave., 4-Dr, Fully loaded, 39,000 miles
- 1991 Mitsubishi Eclipse Turbo 2-Dr, loaded, 29,000 miles
- 1984 Mercury Marquis 4-Dr, 64,000 actual miles
- 1986 Pontiac 6000 STE 4-Dr, Fully loaded, very clean
- 1992 Olds Silhouette, Fully loaded, 9,000 miles
- 1990 Olds Delta 88 4-Dr, fully loaded, 18,000 miles
- 1987 Dodge Omni, good economical work car
- 1990 Ford Crown Victorla, fully loaded, 11,000 miles
- 1986 Olds Clera Brghm 2-Dr, very clean, fully loaded
- 1989 Chevrolet Corsica, 4-Dr, 30,000 miles
- 1990 Chev Geo Prizm 4-Dr, good economical car
- 1988 Oldsmobile Clera, 4-Dr, 62,000 miles
- 1988 Buick Regal, 2-Dr, 37,000 miles
- 1987 Chevrolet Monte Carlo, 2-Dr, 52,000 miles
- 1986 Oldsmobile Delta 88, 2-Dr, 42,000 miles
- 1978 Chev. Mallbu 4-Dr, 75,000 actual miles
- 1986 Buick Skylark 2-Dr, very clean, good school car
- 1985 Chev. Camaro Z28, T-Tops, fully loaded, 38,000 miles
- 1985 Oldsmobile Toronado 2-Dr, one owner
- 1984 Cadillac Seville, very clean
- 1984 Oldsmobile Delta 2-Dr, fully loaded
- 1984 Pontiac Bonneville 4-Dr, good economical work car

USED PICKUPS

- 1990 Chevrolet S10 Blazer, 4x4, 33,000 miles
- 1989 Chev. 1/2 ton Pup 350-V8, cruise, tilt
- 1988 Jeep Cherokee Limited, 4 wheel drive, fully loaded
- 1989 Mazda SR5 Pup, 32,000 miles
- 1990 Chev Astro Van, fully loaded, 40,000 miles
- 1989 Chev Suburban, fully loaded, 49,000 miles
- 1990 Chev. 3/4 ton, 350-V8, 4 speed, 46,000 miles
- 1989 Chev Astro Van, fully loaded, 42,000 miles
- 1986 Ford 1/2 ton, XLT V8, auto trans., only 67,000 miles
- 1990 Chev. Conversion Suburban, fully loaded, 46,000 miles
- 1989 Ford Aeorstar Extended, fully loaded, 42,000 miles
- 1989 Chev 1/2 ton Silverado, loaded, 24,000 miles
- 1986 Ford Ranger, economical work truck
- 1988 GMC Suburban, 58,000 miles
- 1987 Ford, 3/4 ton, 4-wheel drive, XL
- 1987 Ford Bronco II, fully loaded
- 1991 Jeep Cherokee 4-Dr, 4 wheel drive, 52,000 miles
- 1986 GMC Suburban, fully loaded, very clean
- 1991 Chev. Surburan, fully loaded, 32,000 miles
- 1986 Ford 3/4 ton Diesel, 4 wheel drive pickup
- 1986 Isuzu Trooper II, diesel, 4x4
- 1984 Chevrolet, 3/4 ton pickup, good work truck
- 1984 Chev 1/2 ton Silverado, diesel PUP, fully loaded
- 1983 Jeep CJ7, hard top, 39,000 actual miles
- 1983 Chev. S10 Blazer - very clean
- 1980 Chevrolet 1/2 ton, good work truck
- 1983 Chev. 3/4 ton, good work truck

Re-Opening Under
New Management
Squires Salvage

Former Koen Salvage

Buying scrap metal, copper,
aluminum cans, steel.

817-629-8305

1411 W. Main Eastland, TX

BAYER MOTOR COMPANY, INC.

218 E. Grand, Comanche,

915-356-2541

1-800-843-5230



J&J AIR CONDITIONING & APPLIANCES

Maytag Appliances — Frigidaire Appliances

Phone 817-629-2251

201 S. Lamar — Eastland, Tx

License # TA CLB002300C

ASCS Names New Texas Director

Washington — U. S. Sen. Phil Gramm has announced the appointment of Donnie G. Bowman of College Station as state executive director of the Texas Agricultural Stabilization and Conservation Service.

"In these times where programs are so complicated and complex, it is extremely important to have someone in this position who understands first-hand the concerns of ranchers and farmers as they relate to government programs," Gramm said.

"We feel fortunate to have found in Donnie Bowman a first-rate administrator who comes from a rural area with an agricultural background and extensive practical experience," he said.

Bowman has extensive experience in ASCS, covering almost 40 years' service and filling a number of positions. He began as an assistant compliance supervisor in the Lamb County ASCS Office doing summer work in 1954, 1957, 1958 and 1961, advancing to county office trainee and serving as county ASCS office manager in both Dickens and Stephens Counties.

He has been a program specialist in the Commodity Programs Division in the Washington ASCS office and in the Price Support Division of the Texas State ASCS Office. For 15 years, he held the position of administrative officer as well as chief of the Administrative Division in the Texas

Texas To Celebrate Hospital Week May 10 - 16

De Leon Hospital joins hospitals across the state May 10-16 in celebrating Texas Hospital Week. This year's theme is "Round-the-Clock Health Care".

As children, we learn about community helpers, such as the firemen and the policemen. Nurses, pharmacists and other health care professionals are community helpers, too.

"I hope children and adults alike perceive our exceptional team of employees as the dedicated community helpers they are," said Mike Hare, hospital administrator. "Hospitals are committed to the care of their communities' health needs. That's what we are here for."

De Leon Hospital's week-long celebration includes activities that focus on the hospitals' dedication to meeting the community's health needs by providing various services and information to the public. Events scheduled throughout the week include:

Monday - Mobile Blood Bank Unit in De Leon at City Hall for Blood Donation Drive from 3 to 7 p. m.
Blood Pressure Checks and Blood Sugar Checks from 8 to 11 a. m. (no food or drink for 12 hrs.) and Low Fat Nutrition Consults.

Tuesday - Total Cholesterol from 7 to 10 a. m. (\$5 charge).
Wednesday - Blood Pressure and Blood Sugar Checks from 8 to 11 a. m. (no food or drink for 12 hrs.); and Low Fat Nutrition Consults.

Thursday - Total Cholesterol from 7 to 10 a. m. (\$5 charge).
Friday - Blood Pressure and Blood Sugar Checks from 8 to 11 a. m. (no food or drink for 12 hours).

Total cholesterol test consists of the total cholesterol level.
A graduate of West Texas State University with a BBA Degree, he and his wife, Janie, have three children and two grandchildren.
Jerry Harris, chairman of the Texas State ASC Committee, added, "The State Committee is extremely pleased to place in this position a person with vast experience in the administration of ASCS programs and extensive knowledge of agriculture in general. Mr. Bowman's personal interest in production agriculture has carried over into management of his cow-calf production in Grimes County."

National Factor For 1990-91 Disaster Program

David Martin, County Executive Director of the Eastland County ASCS Office, has announced that a national factor of 50.04 percent will be used to calculate payments to producers who filed claims for crop production losses under provisions of the 1990-91 Disaster Program. Eastland County producers filed for \$1,135,292 of crop losses sustained during the 1990 and 1991 crop years.

Payments to Eastland County producers will total \$568,100 after application of the factor.

Martin said qualifying producers' payments were calculated by determining the eligible amount of production loss and multiplying it by the applicable rate.

"Because total payments are limited by the \$995 million allocated by Congress, it was necessary to factor this further," Martin said. "Producers may calculate their payments at once by using this percentage."

All commercially grown crops that

suffered at least a 40 percent production loss due to an identifiable disaster were eligible for payment. The Disaster Program sign-up ended on March 13, 1992 and all supporting documentation was required to be filed by March 27, 1992. Eastland County producers filed for disaster losses totaling \$742,369 in 1990 and \$392,923 in 1991.

The Eastland County ASCS Office is in the process of preparing 506 checks totaling \$568,100. The mailing of payment checks will begin soon.

Dealer For GE Ground Propelled Hexagon Rod Weeder Attachment

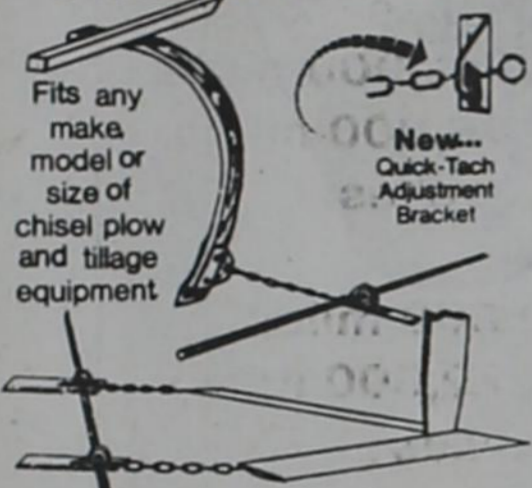

Fits any make model or size of chisel plow and tillage equipment.
New Quick-Tach Adjustment Bracket.
6 Row - \$437.00 4 Row - \$300.00
Underwood Equipment
Rt 1 - Box 49A - Gorman, Tx 76454

Fuel is our only business! **GOCO**
PRIDE REFINING INC.
Reason #18 for using GOCO's Cardlock System
18. Dependable Service
There's lots of reasons to use it!
Located behind Birdsong Peanuts in Gorman

Shop Our Greenhouse For Mother's Day

HANGING BASKETS	EACH	\$5.00
6 INCH POTS GERANIUMS	EACH	\$2.50
ASSORTED BEDDING PLANTS	4 INCH CUPS	75c TO \$1.00
ROSES		
5 GALLON POTS		\$5.00
3 for		\$13.50
ONE GALLON SHRUBS	EACH	\$2.50
POTTING SOIL	40# Bag	\$3.75
COW MANURE	40# Bag	\$2.50

G & H FEEDS, INC.
Phone 734-2501 Gorman, Tx
1 Mile North on Kokomo Hwy.

pitals are committed to the care of their communities' health needs. That's what we are here for."

De Leon Hospital's week-long celebration includes activities that focus on the hospitals' dedication to meeting the community's health needs by providing various services and information to the public. Events scheduled throughout the week include:

Monday - Mobile Blood Bank Unit in De Leon at City Hall for Blood Donation Drive from 3 to 7 p. m.

Blood Pressure Checks and Blood Sugar Checks from 8 to 11 a. m. (no food or drink for 12 hrs.) and Low Fat Nutrition Consults.

Tuesday - Total Cholesterol from 7 to 10 a. m. (\$5 charge).

Wednesday - Blood Pressure and Blood Sugar Checks from 8 to 11 a. m. (no food or drink for 12 hrs.); and Low Fat Nutrition Consults.

Thursday - Total Cholesterol from 7 to 10 a. m. (\$5 charge).

Friday - Blood Pressure and Blood Sugar Checks from 8 to 11 a. m. (no food or drink for 12 hours).

Total cholesterol test consists of the total cholesterol level.

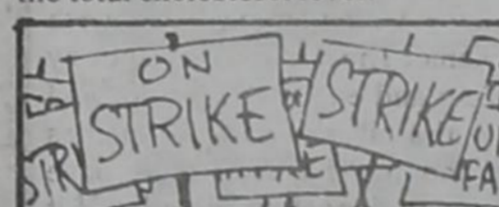

In 1955 there were 363 strikes by workers in the U.S. In 1990 there were 44.

Your Mom Deserves The Best!!!

* Cut & Silk Arrangements
* Variety of Plants and Hanging Baskets

FOSTER FLORAL
Gene and Carolyn Foster
Phone 734-2519
Gorman, Tx

PROPERTY TAX PROTEST AND APPEAL PROCEDURES

The law gives property owners the right to protest actions concerning their property tax appraisals. You may follow these appeal procedures if you have a concern about:

- *the value placed on your property
- *any exemptions that may apply to you
- *the cancellation of an agricultural appraisal
- *the taxable status of your property
- *the local governments which should be taxing your property
- *any action taken by the appraisal district that adversely affected you.

Informal Review
Contact the Eastland County Appraisal District Staff at 817-629-8597 in Eastland, Texas for an informal review.

Review by the Appraisal Review Board
If you can't resolve your problem informally with the appraisal district staff, you may have your case heard by the appraisal review board (ARB).

The ARB is an independent board of citizens that reviews problems with appraisals or other concerns listed above. It has the power to order the appraisal district to make the necessary changes to solve problems. If you file a written request for an ARB hearing (call a notice of protest) before the deadline, the ARB will set your case for a hearing. You'll receive written notice of the time, date and place of the hearing. The hearing will be informal. You and the appraisal district representative will be asked to present evidence about your case. The ARB will make its decision based on the evidence presented. You can get a copy of a protest from the appraisal district office located on the second floor of the Eastland County Courthouse, Eastland, Texas. Note: You shouldn't try to contact ARB members outside of the hearing. The law requires ARB members to sign an affidavit saying that they haven't talked about your case before the ARB hears it.

Review by the District Court
After it decides your case, the ARB must send you a copy of its order by certified mail. If you're not satisfied with the decision, you have the right to appeal to district court. If you choose to go to court, you must start the process by filing a petition within 45 days of the date you receive the ARB's order. If the appraisal district has appraised your property at \$1,000,000 or more, you must file a

notice of appeal with chief appraiser within 15 days of the date you receive the ARB's order.

More information
You can get more information by contacting your appraisal district at 817-629-8597 in Eastland, Texas or visiting the office which is located on the second floor of the Eastland County Courthouse, Eastland, Texas. You can also get a pamphlet describing how to prepare a protest from the appraisal district or from the State Comptroller's Property Tax Division at 4301 Westbank Drive, Building B, Suite 100, Austin, Texas 78746-6565.

Deadline for filing Protests with the ARB* Usual Deadline
On or before May 31 (or 30 days after a notice of appraised value was mailed to you, whichever is later).

Late protests are allowed if you miss the usual deadline for good cause. Good cause is some reason beyond your control, like a medical emergency. The ARB decides whether you have good cause.

Late protests are due the day before the appraisal review board approves records for the year. Contact your appraisal district for more information.

Special Deadlines
For changes of use (the appraisal district informed you that you are losing agricultural appraisal because you changed the use of your land), the deadline is before the 30th day after the notice of the determination was mailed to you.

For ARB changes (the ARB has informed you of a change that increases your tax liability and the change didn't result from a protest you filed), the deadline is before the 30th day after the notice of the determination was mailed to you.

If you believe the appraisal district or ARB should have sent you a notice and did not, you may file a protest until the day before taxes become delinquent (usually February 1). The ARB decides whether it will hear your case based on evidence about whether a required notice was mailed to you.

*The deadline is postponed to the next business day if it falls on a weekend or holiday.

4-H CLUB NEWS

COUNTYWIDE 4-H RECORD BOOK WORKSHOPS

4-Hers...don't forget that your 4-H Record Books are due Monday, July 13th in the Extension office.

Plan to attend a 4-H Record Book Workshop...several are scheduled for your convenience during May which are as follows:

Friday, May 8 - 9:30 to 11:30 a. m.
First United Methodist Church,
Rising Star

Monday, May 18th - 5 to 7 p. m. at
TU Electric in Eastland

The training will be presented by Mrs. Janet Thomas, County Extension Agent-HE, and all record book forms will be available.

4-H Records are the "avenue" to 4-H AWARDS, RECOGNITION, and SCHOLARSHIPS. Texas has the largest 4-H scholarship program in the nation with over \$600,000 awarded annually.

GOOD LUCK TO JUDGING TEAM

Good luck to the Eastland County Range and Pasture Judging Team members which include: Ricky Agnew, Tommy Thompson, Jackie Powledge, Chris Gerhardt and Sam Curtis. They will be competing in the District Judging Contests in San Saba on Saturday, May 9th.

SIX FLAGS DISCOUNT TICKETS

Don't forget to purchase discount tickets to Six Flags over Texas from

the Eastland County 4-H Office, Basement of Courthouse or call 629-2222 for information.

Tickets are available to individuals or groups for \$17.75 (over a \$6.98 savings off regular gate price).

ATTENTION 4-HERS!!!!

All 4-Hers are reminded to make special plans to attend your May 4-H Club meetings.

Officers for 1992-93 will be elected. Every 4-Her will fill out a 1992-93 4-H Club Enrollment Form.

4-H COUNCIL REPORT

Eastland County 4-H Council met Thursday, April 23rd. Many exciting plans are underway for the End of the Year Party, County Camp, and 1992-93 year.

New officers were elected.

End of Year Party plans were made for Saturday, May 23rd at Cisco Junior College Student Union Building. Come and enjoy a fun night of county 4-H fellowship with games, bowling, dancing and more. The fun starts at 7 and ends at 11 p. m. Bring a new or old 4-H friend.

The Council discussed plans for County Camp to be held July 17-18. Comanche County is joining Eastland County at camp this year. We discussed the theme, nemu, workshops and activities. The Planning Committee met on Thursday, April 30th to finalize plans for the event.



Eastland County ASC Presented Certificate

College Station — The Texas State ASC Committee presented the Eastland County ASC Office a Certificate of Appreciation for their demonstration of exceptional ability, dedicated commitment and the performance of outstanding service to ASCS and the farmers and ranchers of Texas in the administration of the 1990/91 Disaster Program. The Texas State ASC Committee presented certificates of appreciation to every county ASC office in Texas.

Jerry D. Harris, Chairman of the Texas State ASC Committee, said, "We would like to take this time to let you know how proud we are of our county office employees and their dedicated service to the farmers and ranchers of Texas."

In addition, Harris stated, "As you know, the county offices just finished the signup period for the 1990 and 1991 Disaster Program. What you may not know is what commitment and hard work it took for the counties to meet the deadlines imposed by Congress. Texas county offices were required to make a report of participation and projected payments not later than Saturday, April 11, 1992. However, computer software sent to the counties to transmit the data was faulty. A fix to the problem was not received until

late Friday night, April 10, and had to be hand-delivered to many offices. Determined county office employees worked long hours Friday and into Saturday night traveling from county to county to ensure information was timely and accurately transmitted to Washington, D.C."

As a result of county office efforts, the disaster information was successfully transmitted to Secretary of Agriculture Ed Madigan, who announced a payment factor of 50.04% and authorized disaster payments of more than \$144,000,000 for Texas producers.

According to Harris, Texas ASCS employees continue to set the example for all government employees. Harris said, "The State ASC Committee are all active farmers and ranchers, who regularly observe these committed professionals do everything they can within the regulations to make farm programs work." Everyone should be aware of how county office employees are working for them.

Blue's Western Wear

"The Most Affordable Western Wear Store in Central Texas"

.We have a large selection of your favorite Western Wear Apparel for MOTHER'S DAY & GRADUATION GIFTS.

.Select from Roper, Panhandle Slim, Wrangler Silver Lake, Rocky Mountain, Roughriders, Banjo, Rafter JX, Hondo, Justin, Diamond J, Tony Lama, Ruddock, Resistol, just to name a few.

Store Hours:
8:30 - 5:30 Mon. - Thurs.
8:30 - 9:00 Fri. - Sat.

112 Main St., Gustine
(915)667-7215

Bearing the health care cost burden

A typical family of four in Texas with an annual income of \$34,000 doled out \$5,349 for health care coverage in 1991. The family's employer contributed \$3,693, bringing the total health care bill to \$9,042.

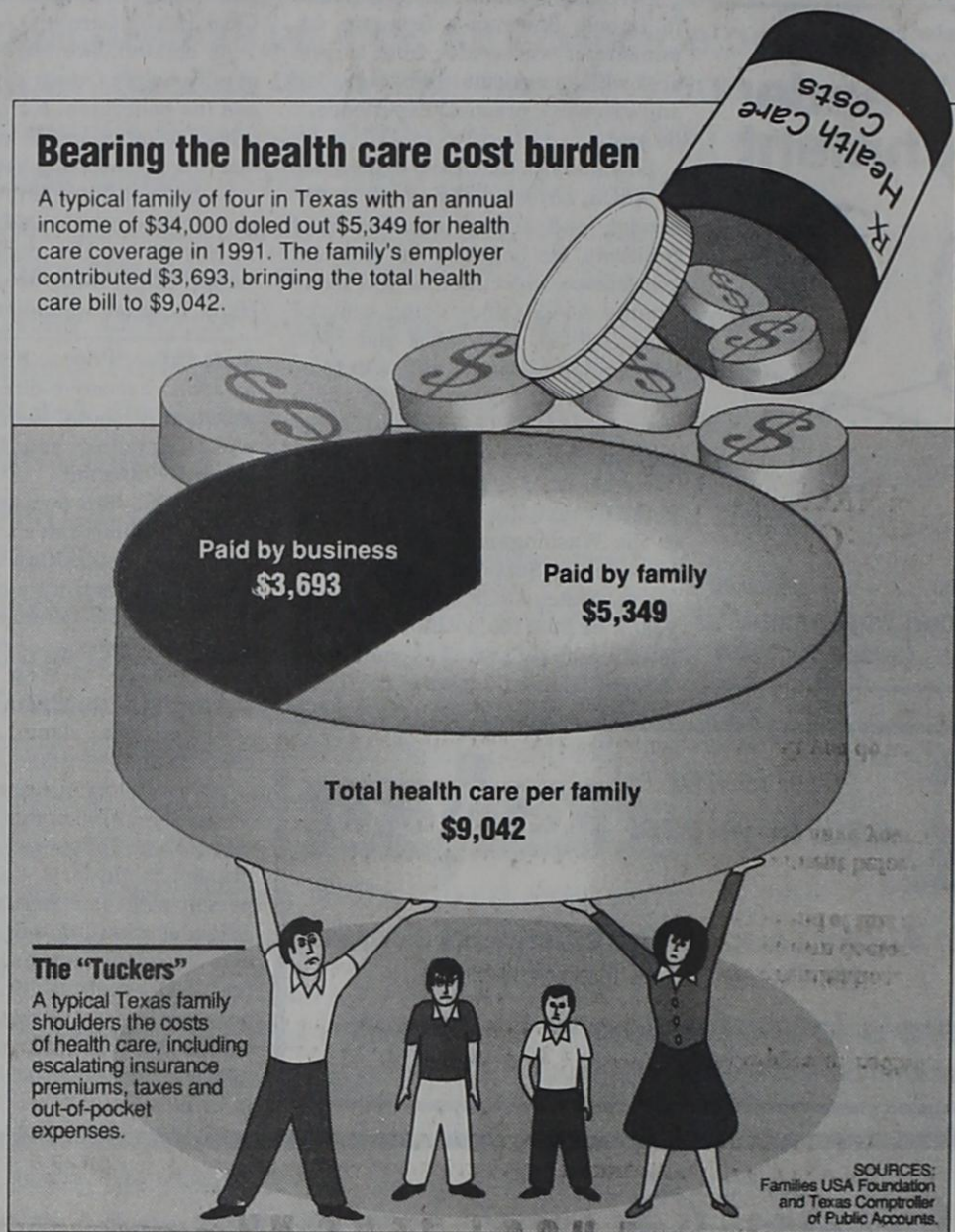

In-Store Introductory Offer SAVE 10% On All C-Line Products

At the Gorman Progress

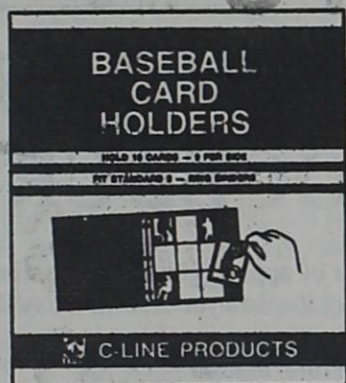

C-LINE PHOTO HOLDERS

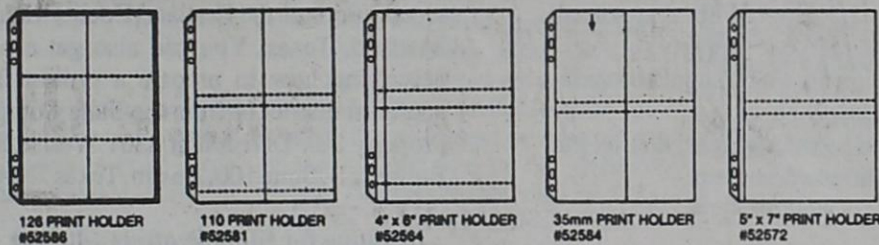

C-LINE POLYPROPYLENE PHOTO HOLDERS ARCHIVAL QUALITY PROTECTION

C-LINE CLEER-ADHEER® DO-IT-YOURSELF LAMINATING SHEETS



C-LINE CLEER-ADHEER® DO-IT-YOURSELF LAMINATING SHEETS

We Now Have a Fax Phone To Send Messages For The Public

Our Rates Are:

Outgoing:

- \$3.00 For the First Page**
- \$2.00 For the Second Page**
- \$1.00 For Each Additional Page**

Incoming:

- \$2.00 For the First Page**
- \$1.00 For Each Additional Page**

Gorman Progress

"The Appreciative Printer"
Phone 734-2410 and 734-2411
Gorman, Texas 76454

MAMMOGRAPHY CAN SAVE YOUR LIFE!!

If you are a healthy woman over 40 who never has had a mammogram, the American Cancer Society recommends that you have this simple life-saving procedure now. Since one woman in 10 develops breast cancer at some point in her lifetime, the urgency is real.

A screening mammogram is an x-ray of the breast using extremely low dosages of radiation (usually comparable to dental x-rays) and is designed to find very early cancers.

A female technologist who is highly trained in mammography will perform the examination. These images are then interpreted by a Board Certified Radiologist, and a report is sent to your own doctor. It takes only a few minutes, and can detect incipient breast cancer as small as the period at the end of this sentence.

Early detection (18 months sooner than a lump can be felt) not only permits treatment before the problem becomes serious, but the cure rate is over 90 percent. Mammography cannot only save your life, but help you avoid the need for disfiguring surgery, too.

You don't need to have been a previous patient of ours to receive this screening, but you do need to make an appointment at a time convenient to you.

PHONE NOW:
817-893-2011 Extension No. 228

APPOINTMENTS WILL BE SCHEDULED:
TUESDAY AND THURSDAY OF EACH WEEK
FROM 1:00 P.M. TO 4:00 P.M.

AT
DE LEON HOSPITAL
407 South Texas Street, De Leon, Texas 76444

KIDS KOUNTRY

201 S. Lamar
(Located in J&J Air Conditioning Building)
Phone 817-629-2828 - Eastland, Texas 76448
Store Hours: Mon. - Fri. 9 a.m. to 6 p.m. - Sat. - 9 a.m. to 2 p.m.

Come Shop Kids Kountry
Size Range: Newborn to 14 - Boys and Girls

See Us For Your Kids Clothes